

APPLICATION: 3 Axle 4S2M AXLE BY AXLE HALDEX SELECT FFV

PART #: **PAK4S2MA-3-HR**

CONTENTS: Glad hand assemblies

- Air tank with installed drain valve and plugged unused ports
- Air tank mounting kit with pads, bolts, washers and lock nuts
- Brake valve(s) are installed and include push to connect fittings
- Hoses with swivel hose ends are installed to valve(s)
- Four speed sensors, sensor bushings and sensor extensions
- Hose separators and sensor cable retainers

OPTIONAL SYSTEMS

PAK4S2MA-3-HS

SPRING BRAKE PRIORITY VALVE

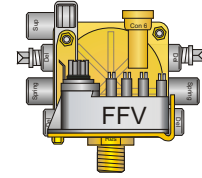

ABS150BB (N9002BB)

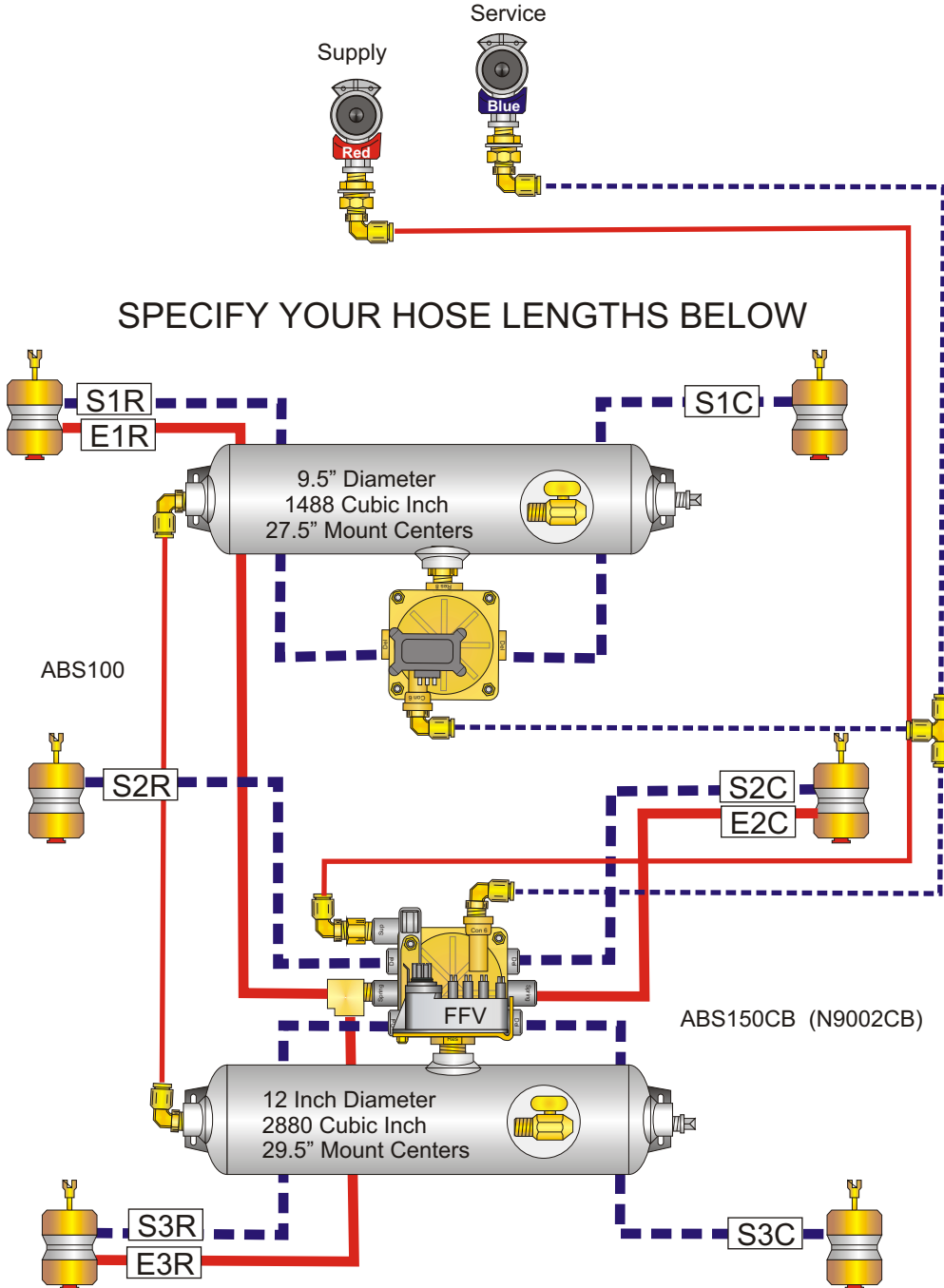

SPECIFY YOUR HOSE LENGTHS BELOW

SUPPLIED WITH THREE SPRING BRAKE CROSSOVER KITS

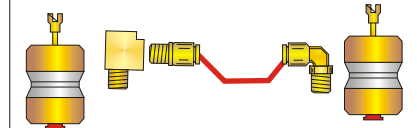

SPECIFY HOSE LENGTH IN INCHES

EMERGENCY:	
E1R	E1C
E2R	E2C
E3R	E3C
SERVICE:	
S1R	S1C
S2R	S2C
S3R	S3C
S4R	S4C

— Service Hose	— Supply Hose
- - - Service Tube	- - - Supply Tube

Specifications:

Hoses meet J1402 & JT106 specifications and are 3/8 ID unless otherwise noted. Reservoirs meet J10B specifications
 Pipe fittings are brass or plated SH80 steel. Push-in style 3/8 tube fittings standard. ABS Electronics pre-tested before shipment.